

FOR OFFICIAL USE



National
Qualifications
SPECIMEN ONLY

Mark

SQ29/N5/01

**Mathematics
Paper 1
(Non-Calculator)**

Date — Not applicable

Duration — 1 hour



* S Q 2 9 N 5 0 1 *

Fill in these boxes and read what is printed below.

Full name of centre

Town

Forename(s)

Surname

Number of seat

Date of birth

Day

Month

Year

Scottish candidate number

Total marks — 40

You may NOT use a calculator.

Attempt ALL questions.

Use blue or black ink. Pencil may be used for graphs and diagrams only.

Write your working and answers in the spaces provided. Additional space for answers is provided at the end of this booklet. If you use this space, write clearly the number of the question you are attempting.

Square-ruled paper is provided at the back of this booklet.

Full credit will be given only to solutions which contain appropriate working.

State the units for your answer where appropriate.

Before leaving the examination room you must give this booklet to the Invigilator.

If you do not, you may lose all the marks for this paper.



* S Q 2 9 N 5 0 1 0 1 *

FORMULAE LIST

The roots of $ax^2 + bx + c = 0$ are $x = \frac{-b \pm \sqrt{(b^2 - 4ac)}}{2a}$

Sine rule: $\frac{a}{\sin A} = \frac{b}{\sin B} = \frac{c}{\sin C}$

Cosine rule: $a^2 = b^2 + c^2 - 2bc \cos A$ or $\cos A = \frac{b^2 + c^2 - a^2}{2bc}$

Area of a triangle: $A = \frac{1}{2} ab \sin C$

Volume of a sphere: $V = \frac{4}{3} \pi r^3$

Volume of a cone: $V = \frac{1}{3} \pi r^2 h$

Volume of a pyramid: $V = \frac{1}{3} Ah$

Standard deviation: $s = \sqrt{\frac{\Sigma(x - \bar{x})^2}{n-1}} = \sqrt{\frac{\Sigma x^2 - (\Sigma x)^2/n}{n-1}}$, where n is the sample size.



* S Q 2 9 N 5 0 1 0 2 *

1. Evaluate

$$2\frac{3}{8} \div \frac{5}{16}$$

2

2. Multiply out the brackets and collect like terms

$$(2x+3)(x^2-4x+1)$$

3

3. Two forces acting on a rocket are represented by vectors \mathbf{u} and \mathbf{v} .

$$\mathbf{u} = \begin{pmatrix} 2 \\ -5 \\ -3 \end{pmatrix} \text{ and } \mathbf{v} = \begin{pmatrix} 7 \\ 4 \\ -1 \end{pmatrix}$$

Calculate $|\mathbf{u} + \mathbf{v}|$, the magnitude of the resultant force.

Express your answer as a surd in its simplest form.

3





MARKS	DO NOT WRITE IN THIS MARGIN
3	
2	

4. Solve the equation

$$2x^2 + 7x - 15 = 0.$$

3

5. Express $\frac{4}{\sqrt{6}}$ with a rational denominator in its simplest form.

2



* S Q 2 9 N 5 0 1 0 4 *

6. Teams in a quiz answer questions on film and sport.
This scattergraph shows the scores of some of the teams.

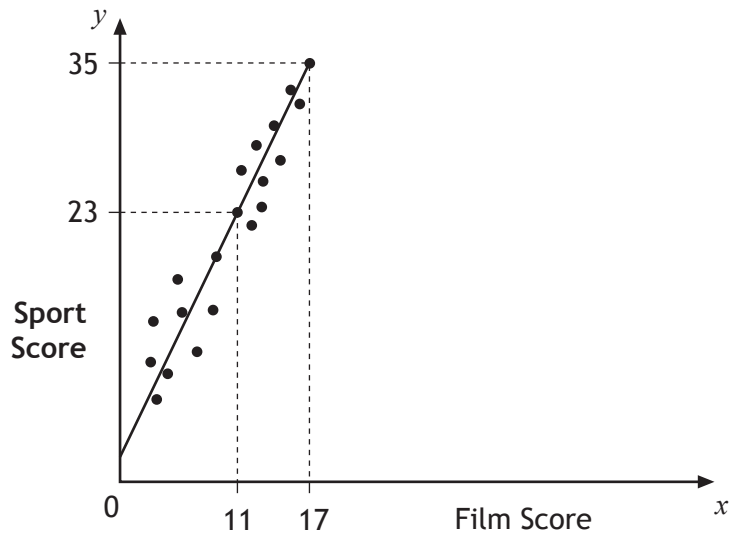

A line of best fit is drawn as shown.

- (a) Find the equation of this straight line. 3

- (b) Use this equation to estimate the sports score for a team with a film score of 8. 1

Total marks 4



MARKS DO NOT WRITE IN THIS MARGIN

7. (a) Multiply out the brackets and simplify:

$$x^{\frac{1}{2}} \left(x^{-\frac{3}{2}} + x^{-\frac{1}{2}} \right).$$

2

(b) Find the exact value of this expression when $x = 6$.

1

Total marks 3

8. Change the subject of the formula $p = \frac{mv^2}{2}$ to v .

3



MARKS DO NOT
WRITE IN
THIS
MARGIN

9. A parabola has equation $y = x^2 - 8x + 19$.

(a) Write the equation in the form $y = (x - p)^2 + q$.

2

(b) Sketch the graph of $y = x^2 - 8x + 19$, showing the coordinates of the turning point and the point of intersection with the y -axis.

3

Total marks 5



* S Q 2 9 N 5 0 1 0 7 *

10. Brian and Bob visit a ski resort. Brian buys 3 full passes and 4 restricted passes. The total cost of his passes is £185.

(a) Write down an equation to illustrate this information.

1

(b) Bob buys 2 full passes and 3 restricted passes.

The total cost of his passes is £130.

Write down an equation to illustrate this information.

1

(c) Find the cost of a restricted pass and the cost of a full pass.

3

Total marks 5

11. Express

$$\frac{4}{x+2} - \frac{3}{x-4}, \quad x \neq -2, x \neq 4$$

as a single fraction in its simplest form.

3



MARKSDO NOT
WRITE IN
THIS
MARGIN

12. A cylindrical pipe has water in it as shown.

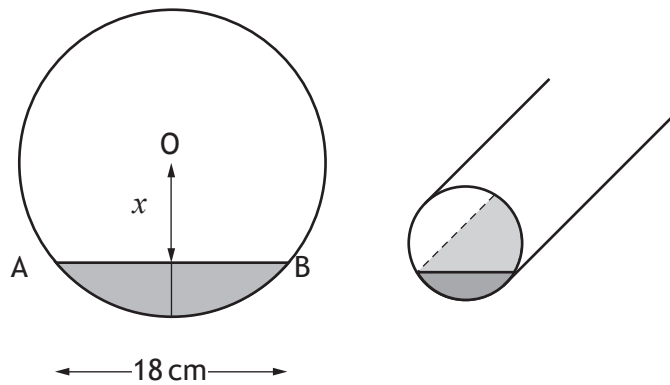

The depth of the water at the deepest point is 5 centimetres.

The width of the water surface, AB, is 18 centimetres.

The radius of the pipe is r centimetres.

The distance from the centre, O, of the pipe to the water surface is x centimetres.

(a) Write down an expression for x in terms of r .

1

(b) Calculate r , the radius of the pipe.

3**Total Marks 4**

[END OF SPECIMEN QUESTION PAPER]



* S Q 2 9 N 5 0 1 0 9 *

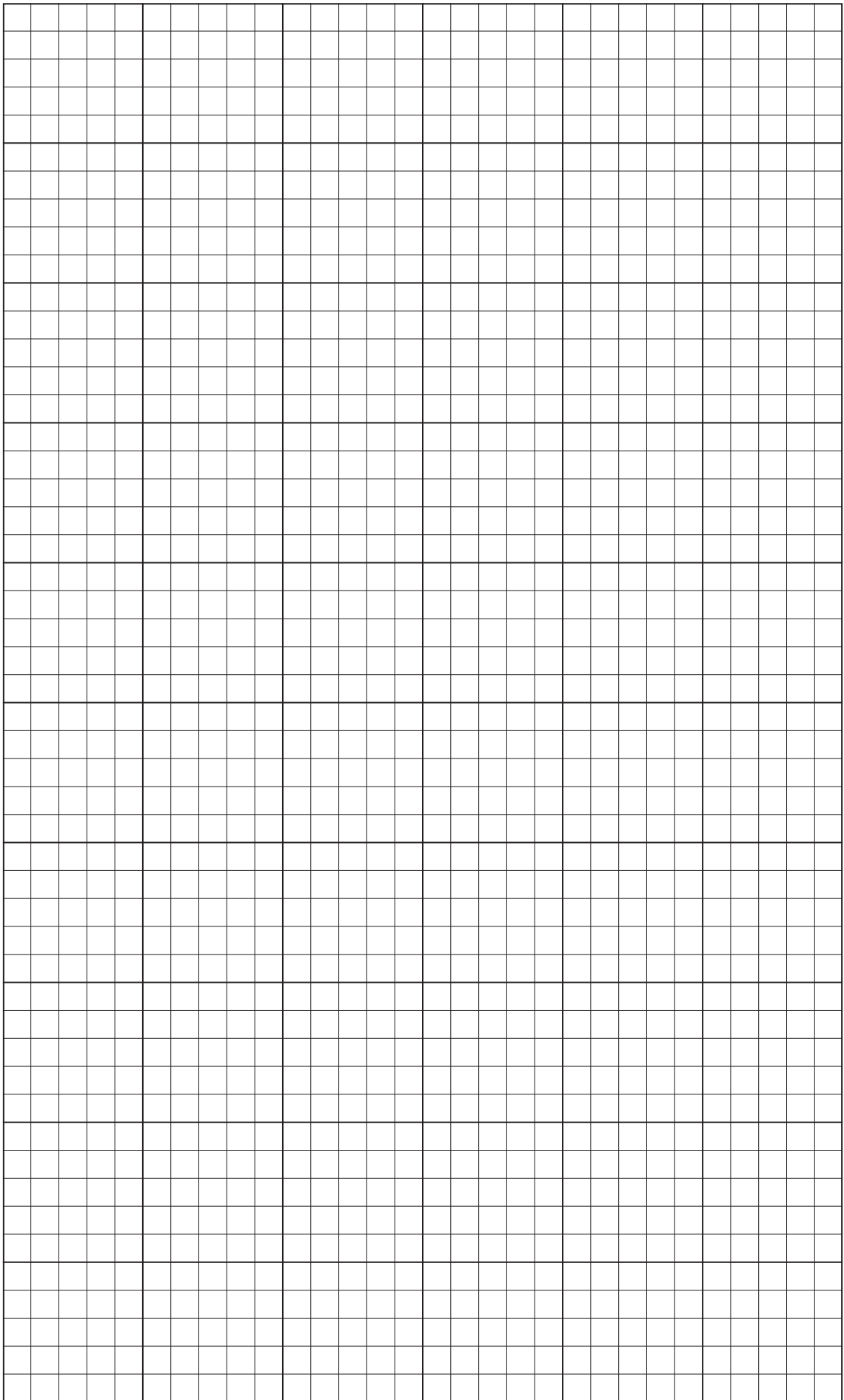

* S Q 2 9 N 5 0 1 1 2 *

FOR OFFICIAL USE



National
Qualifications
SPECIMEN ONLY

Mark

SQ29/N5/02

Mathematics
Paper 2

Date — Not applicable

Duration — 1 hour and 30 minutes



Fill in these boxes and read what is printed below.

Full name of centre

Town

Forename(s)

Surname

Number of seat

Date of birth

Day

Month

Year

Scottish candidate number

Total marks — 50

You may use a calculator.

Attempt ALL questions.

Use **blue** or **black** ink. Pencil may be used for graphs and diagrams only.

Write your working and answers in the spaces provided. Additional space for answers is provided at the end of this booklet. If you use this space, write clearly the number of the question you are attempting.

Square-ruled paper is provided at the back of this booklet.

Full credit will be given only to solutions which contain appropriate working.

State the units for your answer where appropriate.

Before leaving the examination room you must give this booklet to the Invigilator.

If you do not, you may lose all the marks for this paper.



FORMULAE LIST

The roots of $ax^2 + bx + c = 0$ are $x = \frac{-b \pm \sqrt{(b^2 - 4ac)}}{2a}$

Sine rule: $\frac{a}{\sin A} = \frac{b}{\sin B} = \frac{c}{\sin C}$

Cosine rule: $a^2 = b^2 + c^2 - 2bc \cos A$ or $\cos A = \frac{b^2 + c^2 - a^2}{2bc}$

Area of a triangle: $A = \frac{1}{2} ab \sin C$

Volume of a sphere: $V = \frac{4}{3} \pi r^3$

Volume of a cone: $V = \frac{1}{3} \pi r^2 h$

Volume of a pyramid: $V = \frac{1}{3} Ah$

Standard deviation: $s = \sqrt{\frac{\Sigma(x - \bar{x})^2}{n-1}} = \sqrt{\frac{\Sigma x^2 - (\Sigma x)^2/n}{n-1}}$, where n is the sample size.



* S Q 2 9 N 5 0 2 0 2 *

MARKS

DO NOT
WRITE IN
THIS
MARGIN

1. Beth normally cycles a total distance of 56 miles per week.
She increases her distance by 15% each week for the next three weeks.
How many miles will she cycle in the third week?

3

2. There are 3×10^5 platelets per millilitre of blood.
On average, a person has 5.5 litres of blood.
On average, how many platelets does a person have in their blood?
Give your answer in scientific notation.

2



* S Q 2 9 N 5 0 2 0 3 *

3. In the diagram, OABCDE is a regular hexagon with centre M. Vectors \mathbf{a} and \mathbf{b} are represented by \overrightarrow{OA} and \overrightarrow{OB} respectively.

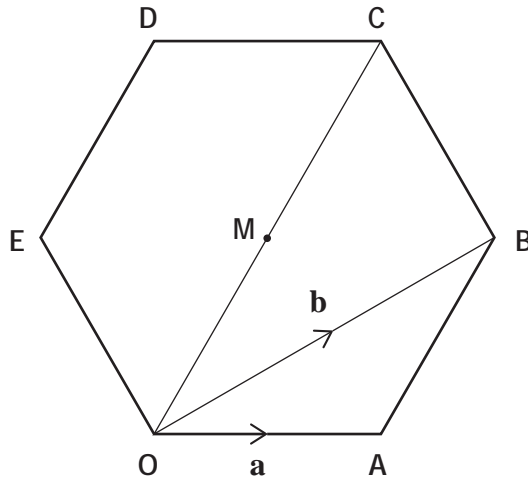

(a) Express \overrightarrow{AB} in terms of \mathbf{a} and \mathbf{b} .

1

(b) Express \overrightarrow{OC} in terms of \mathbf{a} and \mathbf{b} .

1

Total marks 2



4. The graph with equation $y = kx^2$ is shown below.

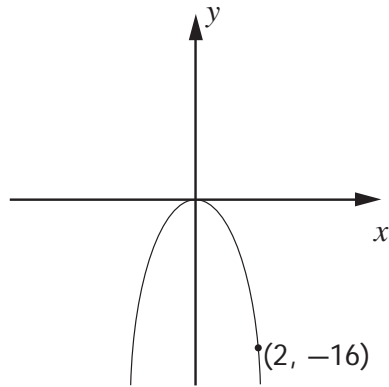

The point $(2, -16)$ lies on the graph.
Determine the value of k .

2

5. In triangle PQR, $PQ = 8$ centimetres, $QR = 3$ centimetres and angle $PQR = 120^\circ$.

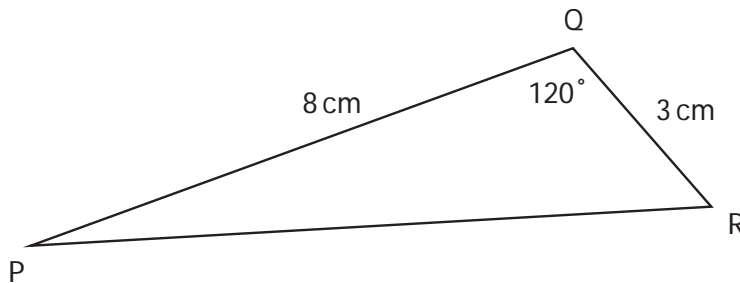

Calculate the length of PR.

3

MARKS

DO NOT
WRITE IN
THIS
MARGIN

6. A child's toy is in the shape of a hemisphere with a cone on top, as shown in the diagram.

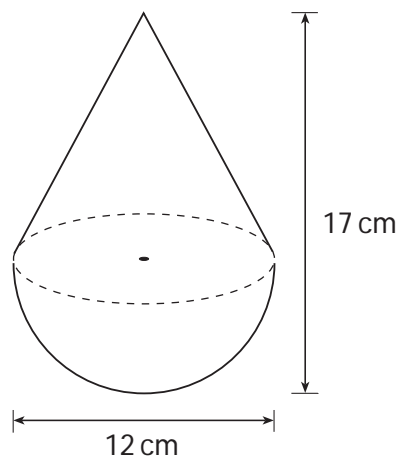

The toy is 12 centimetres wide and 17 centimetres high.

Calculate the volume of the toy.

Give your answer correct to 2 significant figures.

5



MARKS

DO NOT
WRITE IN
THIS
MARGIN

7. This year Adèle paid £465 for her car insurance.
This is an increase of 20% on last year's payment.
How much did Adèle pay last year?

3

8. A frozen food company uses machines to pack sprouts into bags.
A sample of six bags is taken from Machine A and the number of sprouts in
each bag is counted.
The results are shown below.

23 19 21 20 19 24

- (a) Calculate the mean and standard deviation of this sample.

3

- (b) Another sample of six bags is taken from Machine B.
This sample has a mean of 19 and a standard deviation of 2.3.
Write down two valid comparisons between the samples.

2

Total marks 5



MARKS

DO NOT
WRITE IN
THIS
MARGIN

9. Screenwash is available in two different sized bottles, 'Mini' and 'Maxi'.
The bottles are mathematically similar.

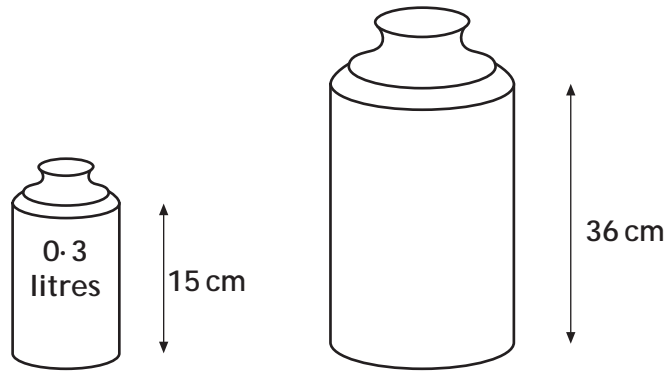

Calculate the volume of the 'Maxi' bottle.

3



10. Part of the graph of $y = a \cos x^\circ + b$ is shown below.

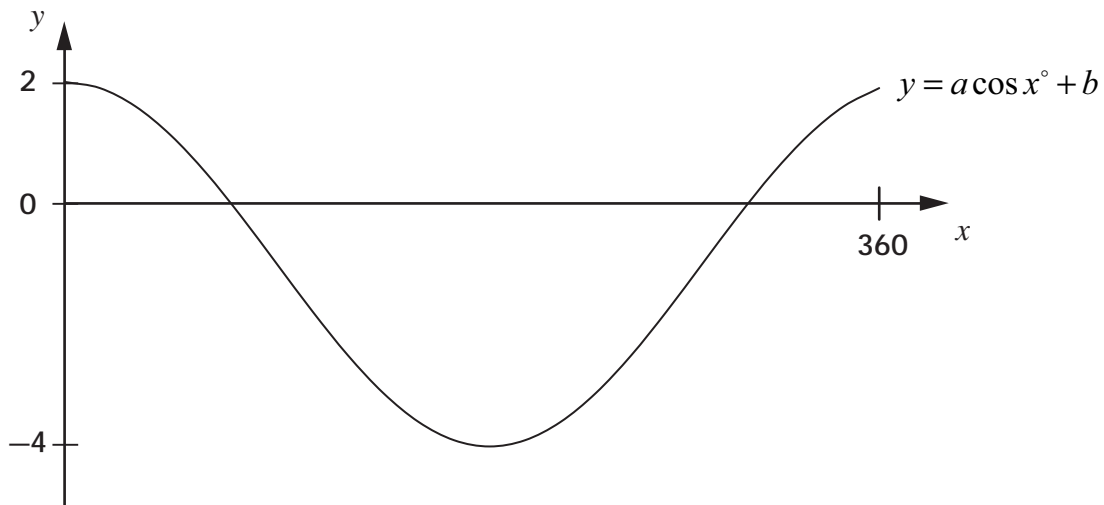

(a) Explain how you can tell from the graph that $a = 3$ and $b = -1$. 2

(b) Calculate the x -coordinates of the points where the graph cuts the x -axis. 4

Total marks 6



11. A cone is formed from a paper circle with a sector removed as shown.
 The radius of the paper circle is 40 centimetres.
 Angle AOB is 110° .

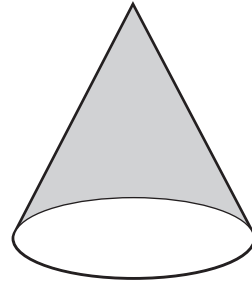
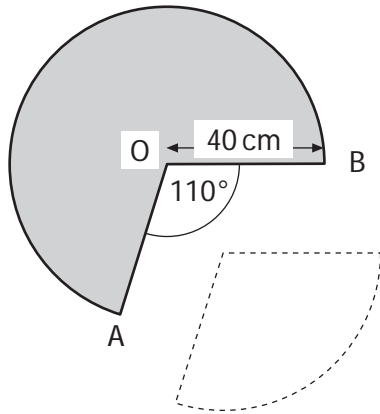

- (a) Calculate the area of the sector removed from the circle. 3
- (b) Calculate the circumference of the base of the cone. 3

Total marks 6





12. Find the range of values of p such that the equation $px^2 - 2x + 3 = 0$, $p \neq 0$, has no real roots.

MARKS

DO NOT
WRITE IN
THIS
MARGIN

4

--



* S Q 2 9 N 5 0 2 1 1 *

13. A yacht sails from a harbour H to a point C, then to a point D as shown below.

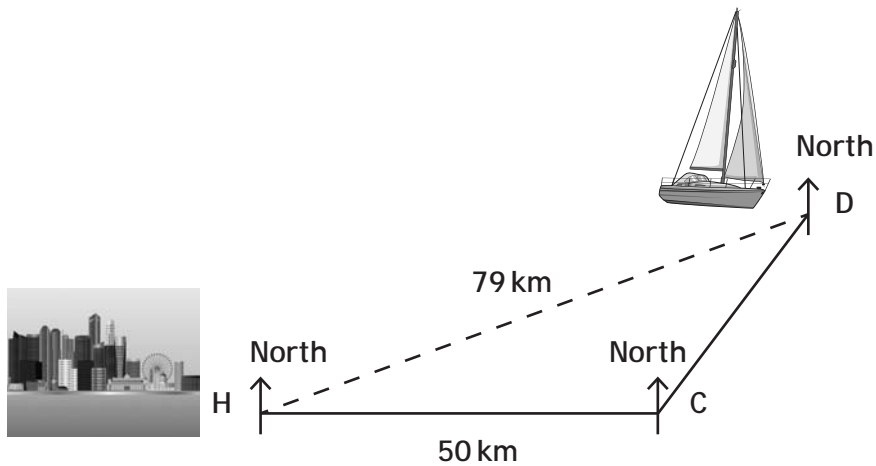

C is 50 kilometres due east of H.

D is on a bearing of 040° from C and is 79 kilometres from H.

- (a) Calculate the size of angle CDH.

4

- (b) Hence, calculate the bearing on which the yacht must sail to return directly to the harbour.

2

Total Marks 6

[END OF SPECIMEN QUESTION PAPER]



* S Q 2 9 N 5 0 2 1 2 *